

# 8" Bench Grinder

(Model 23-840)



PART NO. 900466 (011)  
Copyright © 2001 Delta Machinery



To learn more about DELTA MACHINERY  
visit our website at: [www.deltamachinery.com](http://www.deltamachinery.com).

For Parts, Service, Warranty or other Assistance,

please call **1-800-223-7278** (In Canada call **1-800-463-3582**).

**ESPAÑOL: PÁGINA 13**

# SAFETY RULES

Woodworking can be dangerous if safe and proper operating procedures are not followed. As with all machinery, there are certain hazards involved with the operation of the product. Using the machine with respect and caution will considerably lessen the possibility of personal injury. However, if normal safety precautions are overlooked or ignored, personal injury to the operator may result. Safety equipment such as guards, push sticks, hold-downs, featherboards, goggles, dust masks and hearing protection can reduce your potential for injury. But even the best guard won't make up for poor judgment, carelessness or inattention. Always use common sense and exercise caution in the workshop. If a procedure feels dangerous, don't try it. Figure out an alternative procedure that feels safer. **REMEMBER:** Your personal safety is your responsibility.

This machine was designed for certain applications only. Delta Machinery strongly recommends that this machine not be modified and/or used for any application other than that for which it was designed. If you have any questions relative to a particular application, **DO NOT** use the machine until you have first contacted Delta to determine if it can or should be performed on the product.

**Technical Service Manager**  
**Delta Machinery**  
**4825 Highway 45 North**  
**Jackson, TN 38305**

**(IN CANADA: 505 SOUTHGATE DRIVE, GUELPH, ONTARIO N1H 6M7)**



## **WARNING: FAILURE TO FOLLOW THESE RULES MAY RESULT IN SERIOUS PERSONAL INJURY**

**1. FOR YOUR OWN SAFETY, READ INSTRUCTION MANUAL BEFORE OPERATING THE TOOL.** Learn the tool's application and limitations as well as the specific hazards peculiar to it.

**2. KEEP GUARDS IN PLACE** and in working order.

**3. ALWAYS WEAR EYE PROTECTION.**

**4. REMOVE ADJUSTING KEYS AND WRENCHES.** Form habit of checking to see that keys and adjusting wrenches are removed from tool before turning it "on".

**5. KEEP WORK AREA CLEAN.** Cluttered areas and benches invite accidents.

**6. DON'T USE IN DANGEROUS ENVIRONMENT.** Don't use power tools in damp or wet locations, or expose them to rain. Keep work area well-lighted.

**7. KEEP CHILDREN AND VISITORS AWAY.** All children and visitors should be kept a safe distance from work area.

**8. MAKE WORKSHOP CHILDPROOF** – with padlocks, master switches, or by removing starter keys.

**9. DON'T FORCE TOOL.** It will do the job better and be safer at the rate for which it was designed.

**10. USE RIGHT TOOL.** Don't force tool or attachment to do a job for which it was not designed.

**11. WEAR PROPER APPAREL.** No loose clothing, gloves, neckties, rings, bracelets, or other jewelry to get caught in moving parts. Non-slip footwear is recommended. Wear protective hair covering to contain long hair.

**12. ALWAYS USE SAFETY GLASSES.** Wear safety glasses. Everyday eyeglasses only have impact resistant lenses; they are not safety glasses. Also use face or dust mask if cutting operation is dusty. These safety glasses must conform to ANSI Z87.1 requirements. Note: Approved glasses have Z87 printed or stamped on them.

**13. SECURE WORK.** Use clamps or a vise to hold work when practical. It's safer than using your hand and frees both hands to operate tool.

**14. DON'T OVERREACH.** Keep proper footing and balance at all times.

**15. MAINTAIN TOOLS IN TOP CONDITION.** Keep tools sharp and clean for best and safest performance. Follow instructions for lubricating and changing accessories.

**16. DISCONNECT TOOLS** before servicing and when changing accessories such as blades, bits, cutters, etc.

**17. USE RECOMMENDED ACCESSORIES.** The use of accessories and attachments not recommended by Delta may cause hazards or risk of injury to persons.

**18. REDUCE THE RISK OF UNINTENTIONAL STARTING.** Make sure switch is in "OFF" position before plugging in power cord.

**19. NEVER STAND ON TOOL.** Serious injury could occur if the tool is tipped or if the cutting tool is accidentally contacted.

**20. CHECK DAMAGED PARTS.** Before further use of the tool, a guard or other part that is damaged should be carefully checked to ensure that it will operate properly and perform its intended function – check for alignment of moving parts, binding of moving parts, breakage of parts, mounting, and any other conditions that may affect its operation. A guard or other part that is damaged should be properly repaired or replaced.

**21. DIRECTION OF FEED.** Feed work into a blade or cutter against the direction of rotation of the blade or cutter only.

**22. NEVER LEAVE TOOL RUNNING UNATTENDED. TURN POWER OFF.** Don't leave tool until it comes to a complete stop.

**23. DRUGS, ALCOHOL, MEDICATION.** Do not operate tool while under the influence of drugs, alcohol or any medication.

**24. MAKE SURE TOOL IS DISCONNECTED FROM POWER SUPPLY** while motor is being mounted, connected or re-connected.

**25. THE DUST GENERATED** by certain woods and wood products can be injurious to your health. Always operate machinery in well ventilated areas and provide for proper dust removal. Use wood dust collection systems whenever possible.

**26. ⚠ WARNING: SOME DUST CREATED BY POWER SANDING, SAWING, GRINDING, DRILLING, AND OTHER CONSTRUCTION ACTIVITIES** contains chemicals known to cause cancer, birth defects or other reproductive harm. Some examples of these chemicals are:

- lead from lead-based paints,
- crystalline silica from bricks and cement and other masonry products, and
- arsenic and chromium from chemically-treated lumber.

Your risk from these exposures varies, depending on how often you do this type of work. To reduce your exposure to these chemicals: work in a well ventilated area, and work with approved safety equipment, such as those dust masks that are specially designed to filter out microscopic particles.

**SAVE THESE INSTRUCTIONS**

# ADDITIONAL SAFETY RULES FOR GRINDERS

1. **DO NOT OPERATE** your tool until it is completely assembled and installed according to the instructions.
2. **IF YOU ARE NOT** thoroughly familiar with the operation of grinders, obtain advice from your supervisor, instructor or other qualified person.
3. **USE** only grinding wheels rated for 3600 RPM with a 1/2" arbor hole. **NEVER** use a wheel rated lower than 3600 RPM or attempt to machine an undersize wheel to fit an arbor.
4. **NEVER** use a chipped or cracked grinding wheel. **ALWAYS** inspect each wheel before mounting on the grinder. **REPLACE A CRACKED WHEEL IMMEDIATELY.**
5. **DO NOT** overtighten wheel nut.
6. **ALWAYS** maintain a distance of 1/8" or less between the grinding wheel and the tool rest. Adjust the tool rests as the grinding wheels decrease in size with use.
7. **SECURELY** tighten tool rests so they cannot shift position while in use.
8. **NEVER** grind on a cold wheel. The grinder should always be started and run at idle speed for one full minute before applying work.
9. **NEVER** grind on the side of the wheel. **ALWAYS** grind on the face of the wheel only.
10. **NEVER** apply coolant directly to a grinding wheel. Coolant can weaken the bonding strength of the wheel and cause it to fail. Dip the workpiece into water to cool it.
11. **SPARKS ARE A HAZARD! NEVER** grind near flammable gas or liquids.
12. **ALWAYS MAKE SURE** the wheel guards and eye shields are in place, properly adjusted and secured.
13. **KEEP** the spark guards close to the wheel and re-adjust them as the wheel wears.
14. **MAKE CERTAIN** the blotter and wheel flanges furnished are used to mount the grinding wheels onto the grinder shaft.
15. **STAND** to one side of the wheel when turning on the power.
16. **AVOID** awkward hand positions where a sudden slip could cause a hand to move into the grinding wheel.
17. **ALWAYS** keep hands and fingers away from the grinding wheel.
18. **NEVER** start the grinder with the workpiece pressed against the grinding wheel.
19. **DRESS** the wheel on the face only. Dressing the side of the wheel can cause it to become too thin for safe use.
20. **DO NOT** use a wheel that vibrates. Dress the wheel, replace the wheel, or replace the shaft bearings, if worn.
21. **GRINDING CREATES HEAT.** Do not touch the workpiece until you are sure it has cooled sufficiently.
22. **REDUCE THE RISK** of unintentional starting. Move switch to the "OFF" position in the event of a power failure.
23. **ALWAYS** keep guards in place when using a wire brush or buffing wheel in place of the standard grinding wheel.
24. **SHOULD** any part of your grinder be missing, damaged, or fail in any way, or any electrical component fail to perform properly, shut off switch and remove plug from power supply outlet. Replace missing, damaged or failed parts before resuming operation.
25. **ADDITIONAL** information regarding the safe and proper operation of this product is available from the National Safety Council, 1121 Spring Lake Drive, Itasca, IL 60143-3201 in the Accident Prevention Manual for Industrial Operations and also in the Safety Data Sheets provided by the NSC. Please also refer to the American National Standards Institute ANSI B7.1 Safety Requirements for the use, care, and protection of abrasive wheels; ANSI B11.9 Safety Requirements for the construction, care and use of grinding machines; and the U.S. Department of Labor OSHA 1910.215 Regulations for Abrasive Wheel Machinery.

# UNPACKING AND CLEANING

Carefully unpack the tool and all loose items from the carton. Remove the protective coating from all unpainted parts. This coating may be removed with a soft cloth moistened with kerosene (do not use acetone, gasoline, or lacquer thinner for this purpose).

**⚠WARNING: FOR YOUR OWN SAFETY, DO NOT CONNECT THE GRINDER TO THE POWER SOURCE UNTIL THE MACHINE IS COMPLETELY ASSEMBLED AND YOU HAVE READ AND UNDERSTAND THE ENTIRE INSTRUCTION MANUAL.**

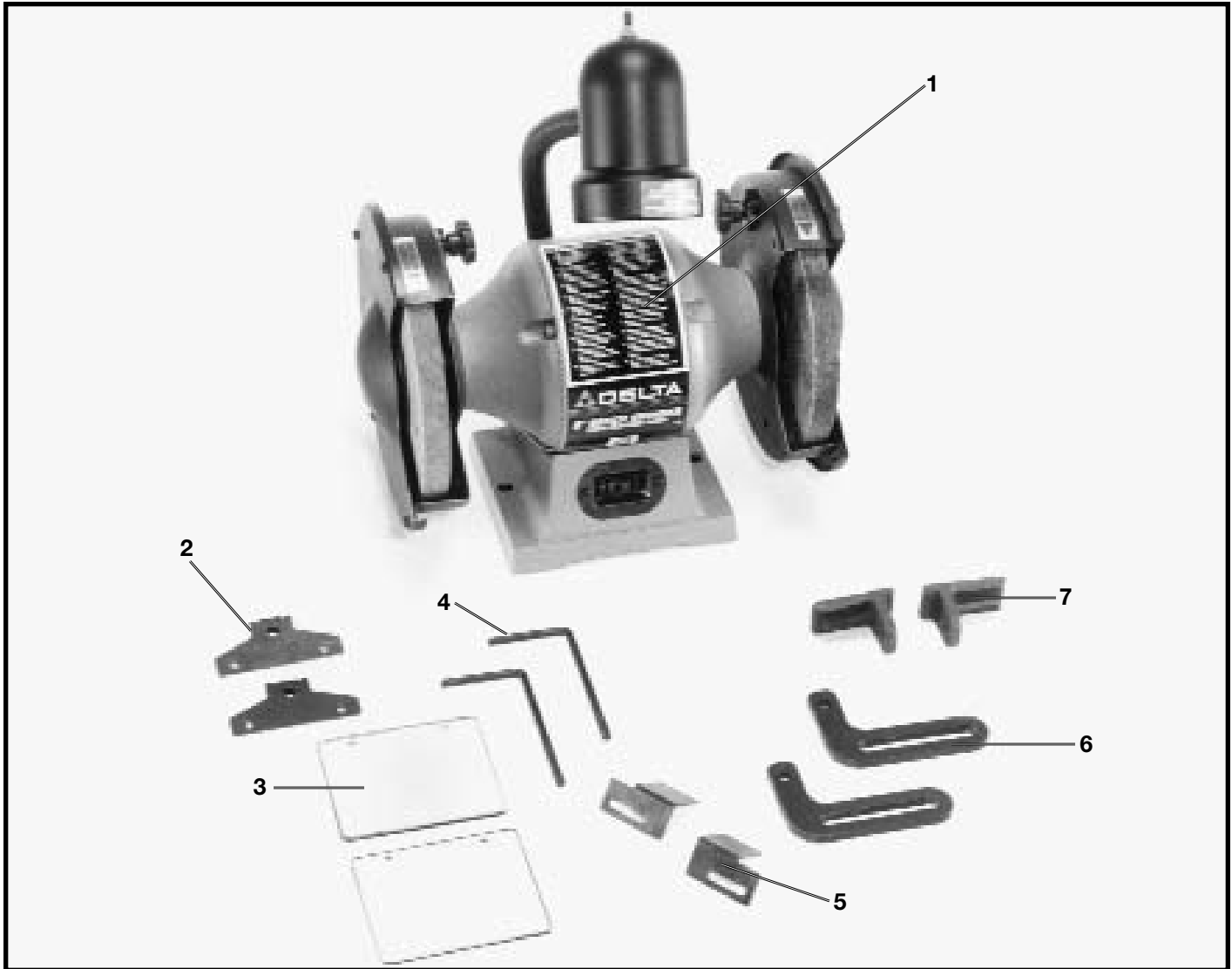

Fig.1

1. Grinder and lamp
2. Eye shield frame (2)
3. Eye shields (2)
4. Rods for eye shields (2)
5. Spark guards (2)
6. Tool rest arms (2)
7. Tool rests (2)

# HARDWARE ILLUSTRATION

Hardware Illustrated in actual size.

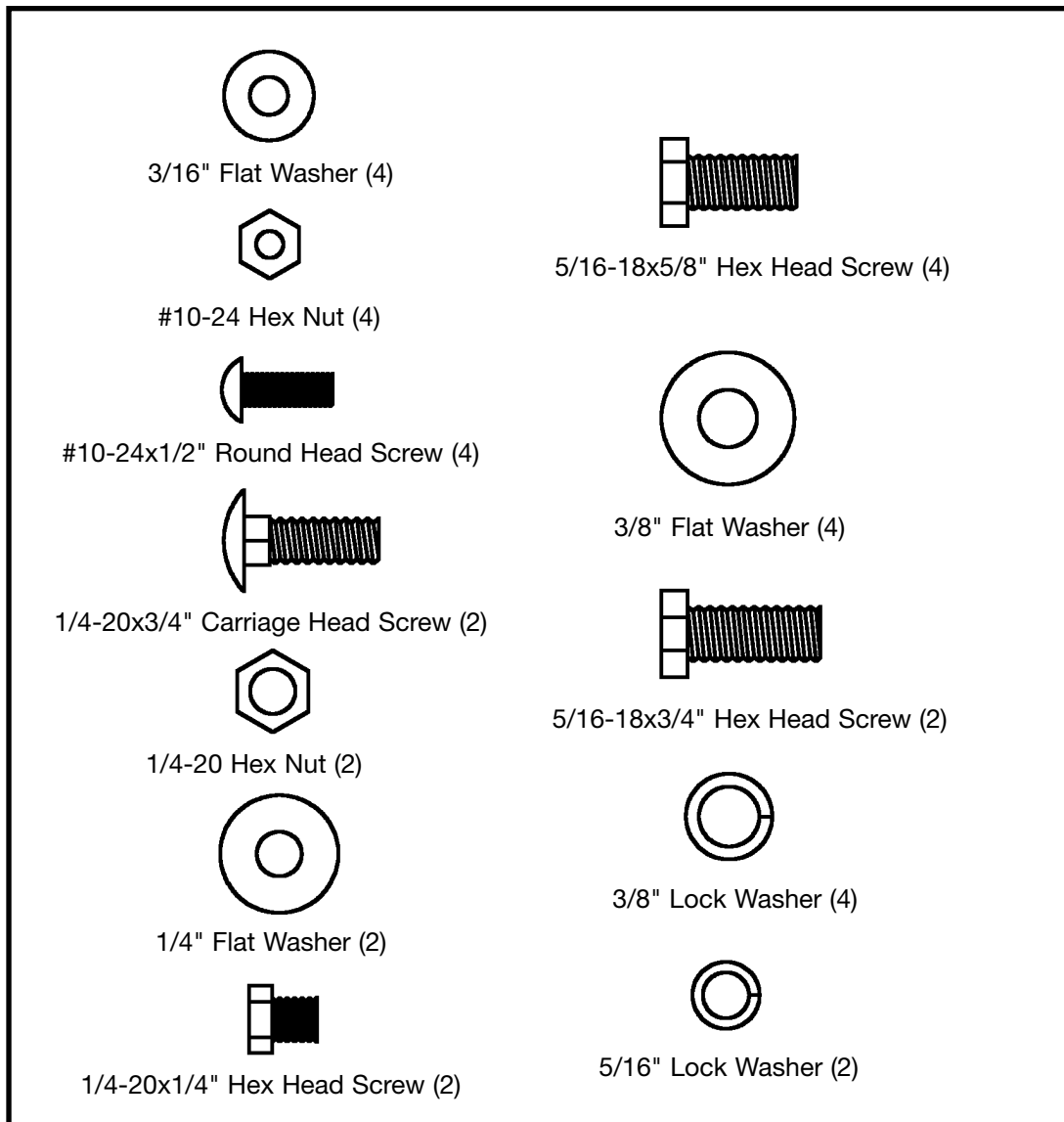

Fig. 2

# ASSEMBLY

## ASSEMBLING TOOL RESTS

1. Assemble adjustable tool rest (A) Fig. 3, to left side of tool rest arm (B), as shown, and fasten with one 5/16-18x3/4" hex head screw and 3/8" lockwasher (C). Assemble the remaining tool rest to the right side of the other tool rest arm in the same manner. Do not completely tighten hardware at this time.

2. Assemble left tool rest assembly (D) Fig. 4, to the inside of left wheel guard (E), and fasten with two 5/16-18x5/8" screws (F) and 3/8" flat washers (G) as shown.

3. Assemble right tool rest assembly to the inside of right wheel guard and fasten with two 5/16-18x5/8" hex head screws and 3/8" flat washers in the same manner.

4. Each tool rest assembly (D) Fig. 4, is adjustable so it can be positioned slightly below the centerline of the wheel and as close to the grinding wheel as possible, giving maximum support to the piece that is being ground. A distance of 1/8-inch or less between the grinding wheel and the inside edge of the tool rest should always be maintained. When the tool rest is positioned correctly, tighten hardware (C) and (F). As the grinding wheel wears down to a smaller diameter, re-adjust the tool rest closer to the wheel. Freehand grinding without the use of a tool rest should always be done on the lower quarter of the wheel.

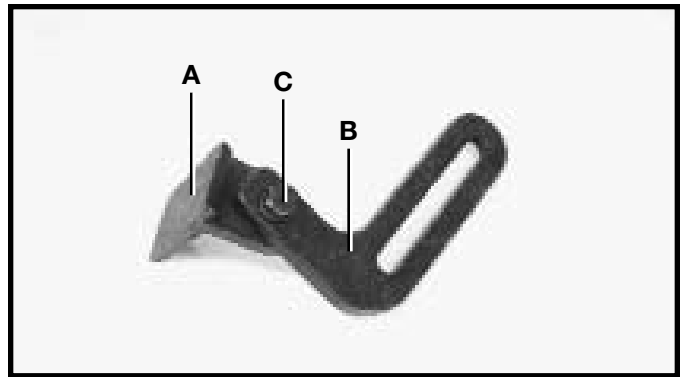

Fig. 3

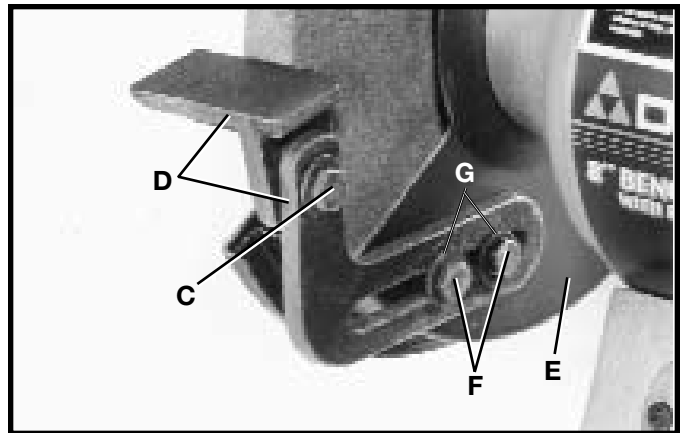

Fig. 4

## ASSEMBLING SPARK GUARDS

Attach spark guard (A) Fig. 5, to each wheel guard, using the 1/4-20x1/4" hex head screw (B) and 1/4" washer (C) as shown. The spark guard (A) should be adjusted as close as possible to the grinding wheel so that sparks never strike the operator's hand. As the wheels wear down, the spark guard (A) should be adjusted accordingly.

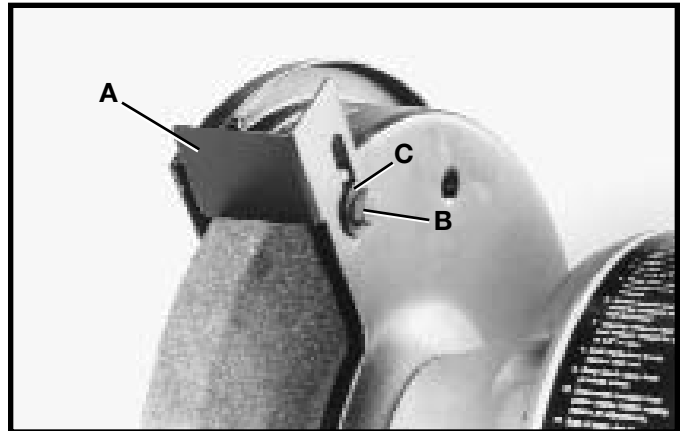

Fig. 5

## ASSEMBLING EYE SHIELDS

Your grinder is supplied with two eye shields for operator protection. Assemble eye shields as follows:

1. Place shield (A) Fig. 6, under the lip of frame (B). Line up the two holes in the shield with the two holes in the frame and fasten together using two #10-24x1/2" round head screws (C), 3/16" flat washers (D), and #10-24 hex nuts (E). Assemble the other shield in the same manner.

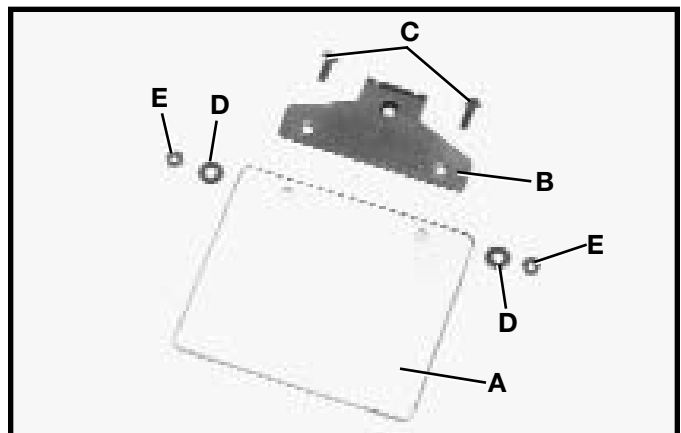

Fig. 6

2. Insert the short end of mounting rod (F) Fig. 7, into hole of frame (B) and fasten in place with 1/4-20x3/4" carriage head screw (G), 5/16" lock washer (H), and 1/4-20 hex nut (I).

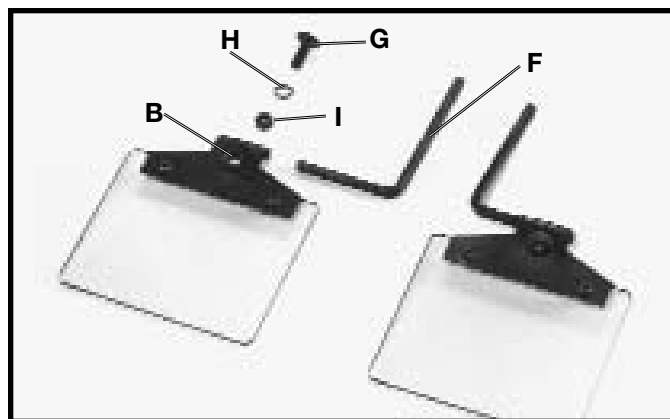

Fig. 7

3. Assemble long end of eye shield mounting rod (F) Fig. 8, to the side of each wheel guard using bracket (J), 3/8" lockwasher, and locking knob (L). The eye shield (A) is fully adjustable so it can be put in any position by moving the shield (A) or loosening locking knob (L) and repositioning rod (F). Assemble the remaining eye shield to the other wheel guard in the same manner.

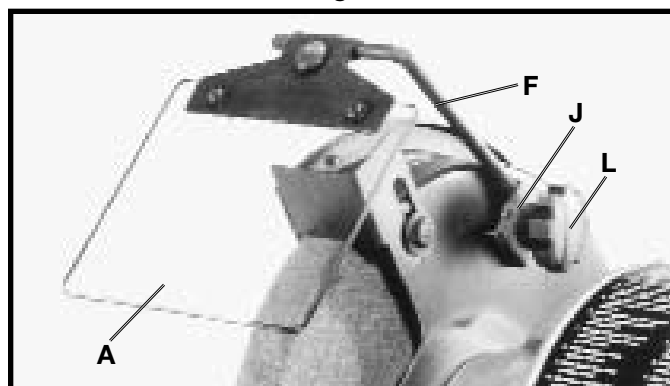

Fig. 8

## FASTENING GRINDER TO SUPPORTING SURFACE

IF DURING OPERATION THERE IS ANY TENDENCY FOR THE GRINDER TO TIP OVER, SLIDE OR "WALK" THE GRINDER MUST BE SECURED TO THE SUPPORTING SURFACE THROUGH THE HOLES (A) FIG. 9, IN THE GRINDER BASE.



Fig. 9

## CONNECTING TOOL TO POWER SOURCE

### POWER CONNECTIONS

A separate electrical circuit should be used for your tools. This circuit should not be less than #12 wire and should be protected with a 20 Amp time lag fuse. If an extension cord is used, use only 3-wire extension cords which have 3-prong grounding type plugs and 3-hole receptacles which accept the tool's plug. Before connecting the motor to the power line, make sure the switch is in the "OFF" position and be sure that the electric current is of the same characteristics as indicated on the tool. All line connections should make good contact. Running on low voltage will damage the motor.

## MOTOR SPECIFICATIONS

Your tool is wired for 120 volt, 60 HZ alternating current. Before connecting the tool to the power source, make sure the switch is in the "OFF" position. The motor provides a no-load speed of 3500 RPM.

## GROUNDING INSTRUCTIONS



**WARNING: THIS TOOL MUST BE GROUNDED WHILE IN USE TO PROTECT THE OPERATOR FROM ELECTRIC SHOCK.**

1. All grounded, cord-connected tools:  
In the event of a malfunction or breakdown, grounding provides a path of least resistance for electric current to reduce the risk of electric shock. This tool is equipped with an electric cord having an equipment-grounding conductor and a grounding plug. The plug must be plugged into a matching outlet that is properly installed and grounded in accordance with all local codes and ordinances.

Do not modify the plug provided - if it will not fit the outlet, have the proper outlet installed by a qualified electrician.

Improper connection of the equipment-grounding conductor can result in risk of electric shock. The conductor with insulation having an outer surface that is green with or without yellow stripes is the equipment-grounding conductor. If repair or replacement of the electric cord or plug is necessary, do not connect the equipment-grounding conductor to a live terminal.

Check with a qualified electrician or service personnel if the grounding instructions are not completely understood, or if in doubt as to whether the tool is properly grounded.

Use only 3-wire extension cords that have 3-prong grounding type plugs and 3-hole receptacles that accept the tool's plug, as shown in Fig. 10.

Repair or replace damaged or worn cord immediately.

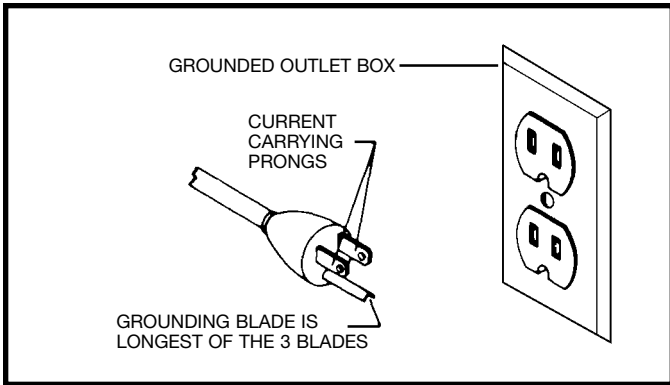

Fig. 10

2. Grounded, cord-connected tools intended for use on a supply circuit having a nominal rating less than 150 volts:

This tool is intended for use on a normal 120-volt circuit and has a grounded plug that looks like the plug illustrated in Fig. 10.

If a properly grounded outlet is not available, a temporary adapter, shown in Fig. 11, may be used for connecting the 3-prong grounding type plug to a 2-hole receptacle. The temporary adapter should be used only until a properly grounded outlet can be installed by a qualified electrician. The green colored rigid ear, lug, or the like extending from the adapter must be connected to a permanent ground such as a properly grounded outlet box cover. Whenever the adapter is used, it must be held in place with a metal screw.

**NOTE: In Canada, the use of a temporary adapter is not permitted by the Canadian Electric Code.**

**⚠ WARNING: IN ALL CASES, MAKE CERTAIN THE RECEPTACLE IN QUESTION IS PROPERLY GROUNDED. IF YOU ARE NOT SURE HAVE A QUALIFIED ELECTRICIAN CHECK THE RECEPTACLE.**

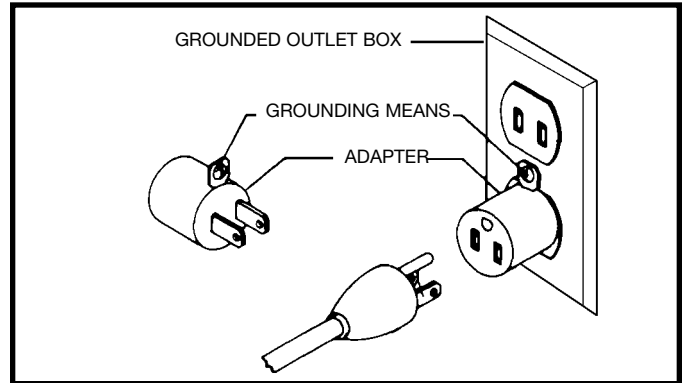

Fig. 11

## EXTENSION CORDS

Use proper extension cords. Make sure your extension cord is in good condition and is a 3-wire extension cord which has a 3-prong grounding type plug and a 3-hole receptacle which will accept the tool's plug. When using an extension cord, be sure to use one heavy enough to carry the current of the tool. An undersized cord will cause a drop in line voltage, resulting in loss of power and overheating. Fig. 12 shows the correct gauge to use depending on the cord length. If in doubt, use the next heavier gauge. The smaller the gauge number, the heavier the cord.

MINIMUM GAUGE EXTENSION CORD			
RECOMMENDED SIZES FOR USE WITH STATIONARY ELECTRIC TOOLS			
Ampere Rating	Volts	Total Length of Cord in Feet	Gauge of Extension Cord
0-6	120	up to 25	18 AWG
0-6	120	25-50	16 AWG
0-6	120	50-100	16 AWG
0-6	120	100-150	14 AWG
6-10	120	up to 25	18 AWG
6-10	120	25-50	16 AWG
6-10	120	50-100	14 AWG
6-10	120	100-150	12 AWG
10-12	120	up to 25	16 AWG
10-12	120	25-50	16 AWG
10-12	120	50-100	14 AWG
10-12	120	100-150	12 AWG
12-16	120	up to 25	14 AWG
12-16	120	25-50	12 AWG
12-16	120	GREATER THAN 50 FEET NOT RECOMMENDED	

Fig. 12



# FLEXIBLE LAMP

The flexible lamp operates independently of the grinder. To turn the lamp on and off, rotate switch (A) Fig. 13.

**⚠WARNING:** To reduce the risk of fire, use 50 watt or less, 120 volt, reflector track type light bulb (not supplied). A standard household light bulb should not be used. The reflector track type light bulb should not extend below the lamp shade.



Fig. 13

# STARTING AND STOPPING GRINDER

The switch (A) Fig. 14, is located on the front of the grinder. To turn the grinder "ON" push the left hand portion of the switch, and to turn the grinder "OFF" push the right hand portion of the switch

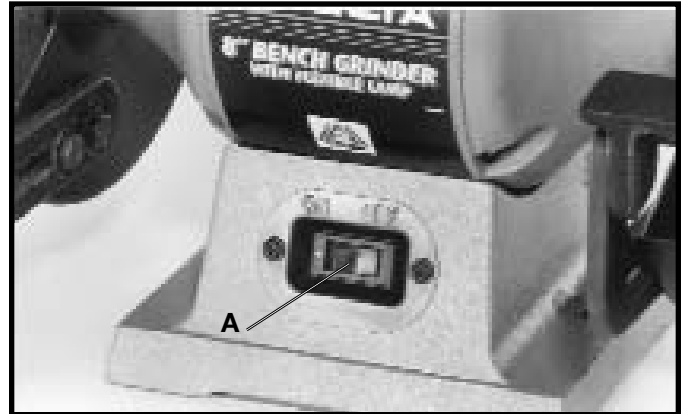

Fig. 14

# GRINDING WHEELS

**⚠WARNING: THE USE OF ACCESSORIES AND ATTACHMENTS NOT RECOMMENDED BY DELTA MAY RESULT IN RISK OF INJURIES.** Grinding wheels used with this grinder should be rated for 3600 RPM or higher and be 8" in diameter with a 1/2" arbor hole.

Two aluminum oxide grinding wheels are supplied with your grinder: one 36 grit and one 60 grit. For best grinding results, and to maintain good balance, always keep the wheels properly dressed. Do not force the work against a cold wheel. The grinding wheel should always be run at idle speed for one full minute before applying work. It is recommended that only balanced wheels be used with your grinder. The use of balanced wheels adds years to the life of the bearings on the grinder and by eliminating the most common source of vibration, more accurate work is accomplished.

# DRESSING A GRINDING WHEEL

When dressing a grinding wheel, use a suitable silicone carbide stick type dresser, as shown in Fig. 15. Bring the dresser forward on the tool rest until it just touches the high point on the face of the wheel and dress the wheel by moving the dresser back and forth. Repeat this operation until the face of the grinding wheel is clean and the corners of the wheels are square.

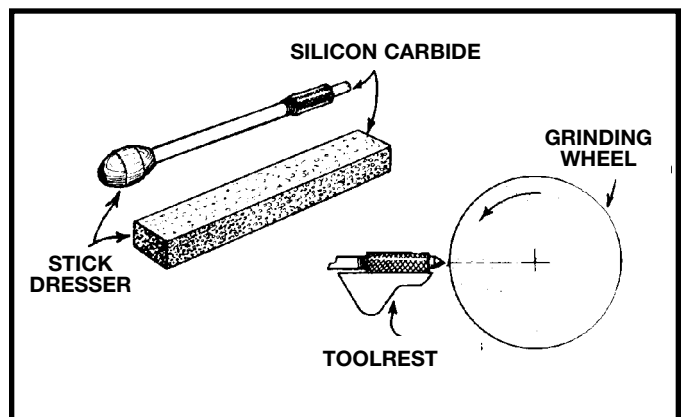

Fig. 15

# CHANGING GRINDING WHEELS

When changing wheels, simply remove four screws (A) Fig. 16, and remove the side cover (B). To prevent shaft rotation, place a wedge (C) Fig. 17, and the wheel guard (D). Facing the front of the grinder: to replace the grinding wheel on the right, turn the arbor nut (E) Fig. 17, counterclockwise to loosen; clockwise to tighten the arbor nut. To replace the wheel on the left side of the grinder, turn the arbor nut (E) clockwise to loosen; counterclockwise to tighten the arbor nut.

**⚠ WARNING: DO NOT OVERTIGHTEN WHEEL NUTS WHEN INSTALLING GRINDING WHEELS. TIGHTEN WHEEL NUT ENOUGH TO DRIVE THE WHEEL AND PREVENT SLIPPAGE.**

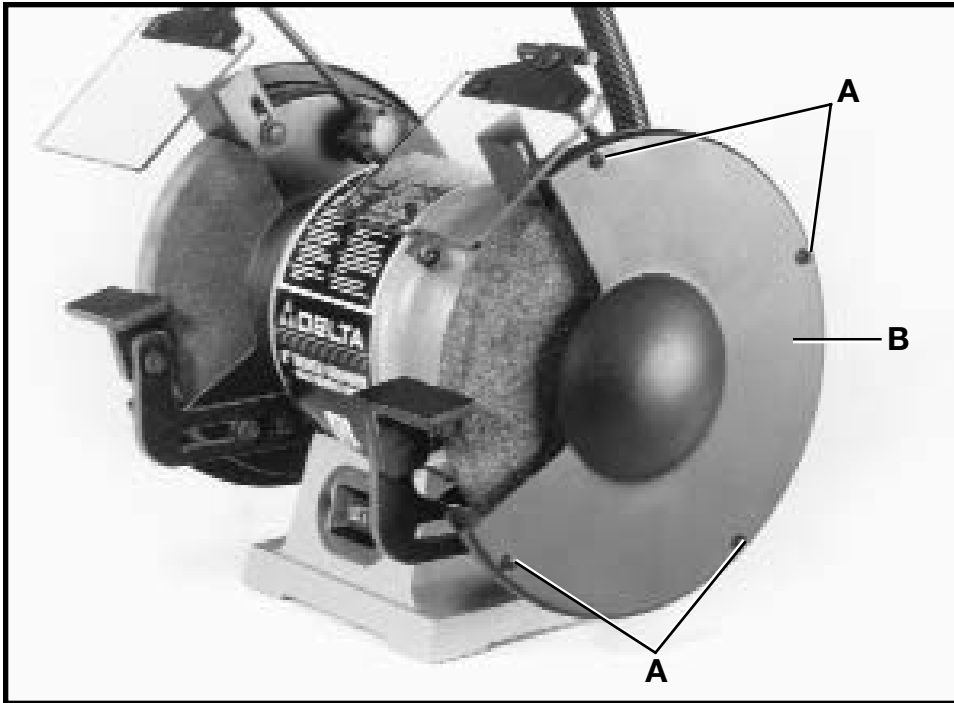

Fig. 16

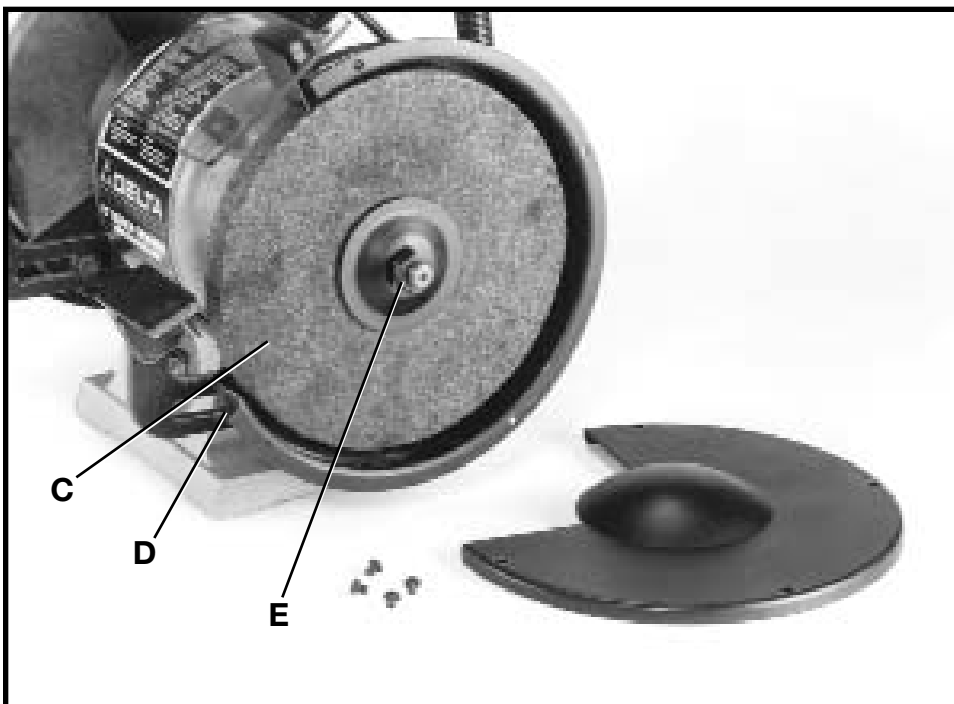

Fig. 17

# OPERATIONS

**IMPORTANT: KEEP SPARK GUARDS AND EYE SHIELDS IN PLACE AT ALL TIMES.**

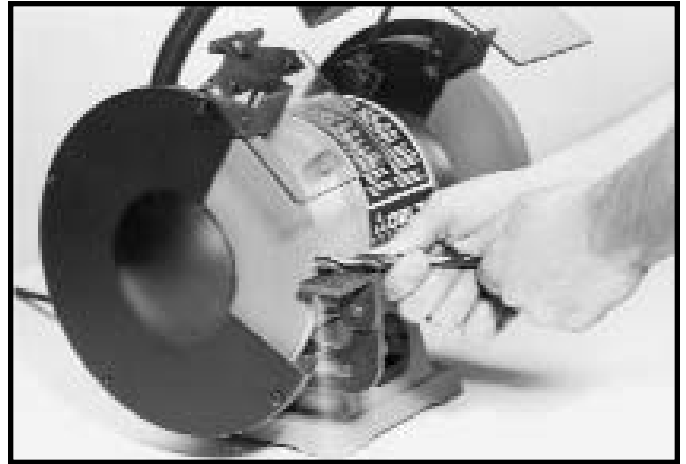

Fig. 18

Figures 18, 19, and 20 illustrate several typical operations that can be accomplished using the grinder. Each tool rest should be positioned a little below the center of the grinding wheel and adjusted so the edge of the tool rest is as close as possible to the grinding wheel for maximum support to the piece that is being ground. This is the most practical and safest position for general work.

As the grinding wheel wears down to a smaller diameter, readjust the tool rest closer to the grinding wheel. A distance of 1/8" or less between the grinding wheel and the edge of the tool rest should always be maintained. Free-hand grinding without the use of the tool rest should always be done on the lower quarter of the grinding wheel. Read the **"SAFETY RULES"** in the front of this manual and follow them while operating this tool.

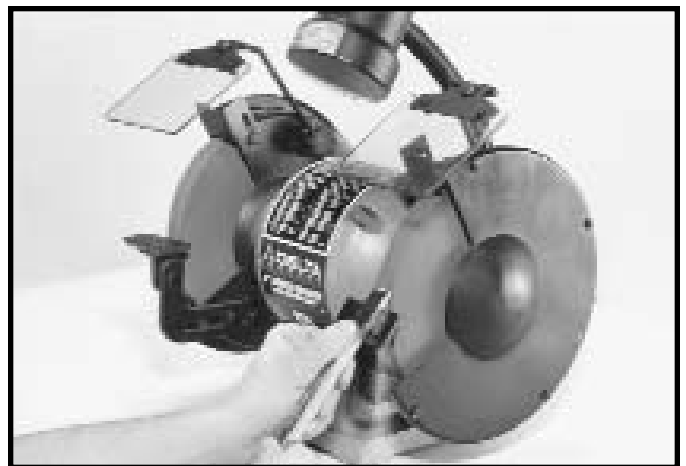

Fig. 19

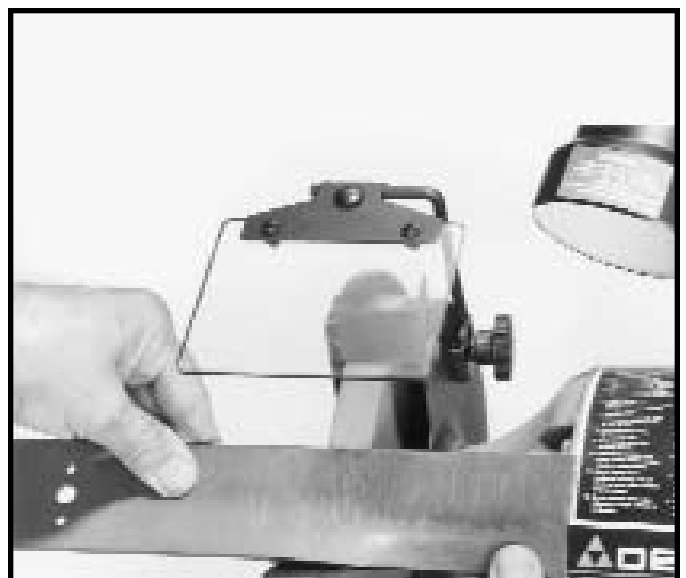

Fig. 20

# ACCESSORIES

A complete line of accessories is available from your Delta Supplier, Porter-Cable Delta Factory Service Centers, and Delta Authorized Service Stations. Please visit our Web Site [www.deltamachinery.com](http://www.deltamachinery.com) for a catalog or for the name of your nearest supplier.



**WARNING:** Since accessories, other than those offered by Delta, have not been tested with this product, use of such accessories could be hazardous. For safest operation, only Delta recommended accessories should be used with this product.



## PARTS, SERVICE OR WARRANTY ASSISTANCE

All Delta Machines and accessories are manufactured to high quality standards and are serviced by a network of Porter-Cable Delta Factory Service Centers and Delta Authorized Service Stations. To obtain additional information regarding your Delta quality product or to obtain parts, service, warranty assistance, or the location of the nearest service outlet, please call 1-800-223-7278 (In Canada call 1-800-463-3582).



### Delta Building Trades and Home Shop Machinery Two Year Limited Warranty

Delta will repair or replace, at its expense and at its option, any Delta machine, machine part, or machine accessory which in normal use has proven to be defective in workmanship or material, provided that the customer returns the product prepaid to a Delta factory service center or authorized service station with proof of purchase of the product within two years and provides Delta with reasonable opportunity to verify the alleged defect by inspection. Delta may require that electric motors be returned prepaid to a motor manufacturer's authorized station for inspection and repair or replacement. Delta will not be responsible for any asserted defect which has resulted from normal wear, misuse, abuse or repair or alteration made or specifically authorized by anyone other than an authorized Delta Service facility or representative. Under no circumstances will Delta be liable for incidental or consequential damages resulting from defective products. This warranty is Delta's sole warranty and sets forth the customer's exclusive remedy, with respect to defective products; all other warranties, express or implied, whether of merchantability, fitness for purpose, or otherwise, are expressly disclaimed by Delta.